

# MDS-3 Motor-driven Siren

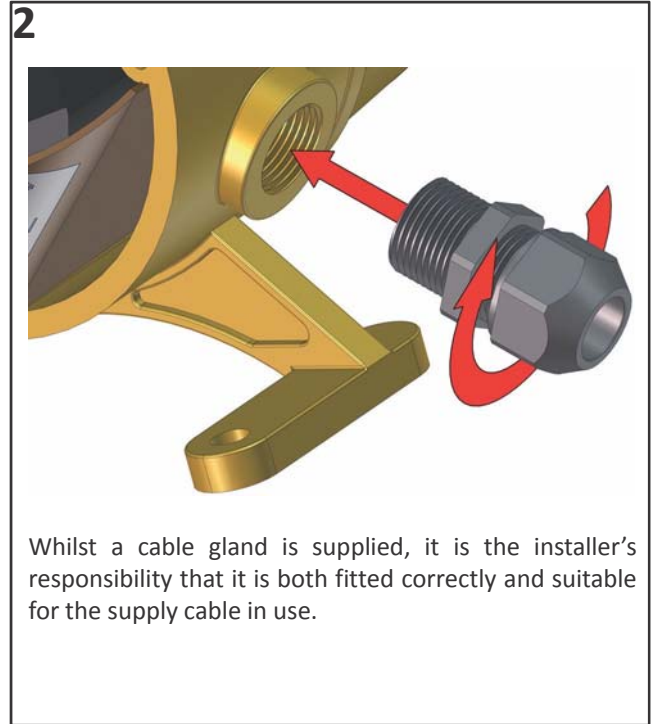

**1**

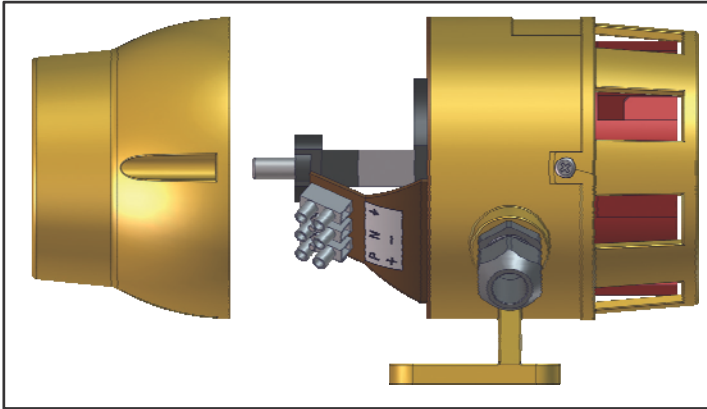
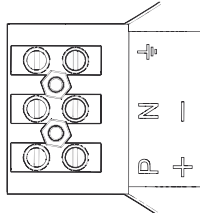

| MDS-3/UC/12-24 | MDS-3/AC/115/ | MDS-3/AC/230/ |
|----------------|---------------|---------------|
|                | Earth         | Earth         |
| -ve (0V)       | N             | N             |
| +ve (11-26Vuc) | P (115Vac)    | P (230Vac)    |

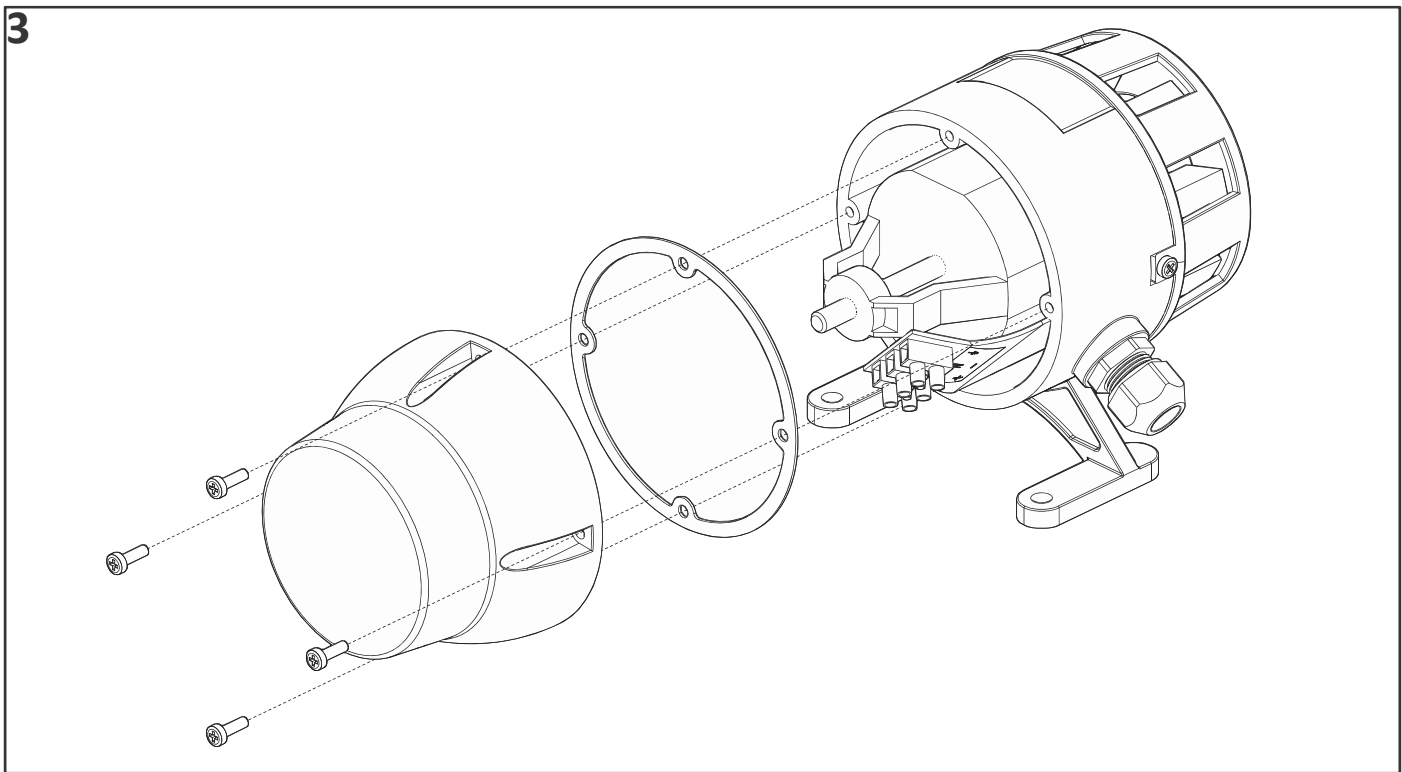

**Note:**

The unit should ideally be mounted in a horizontal position. In environments where dirt or particles may fall onto the moving parts of the siren's impeller, it is recommended to mount the unit with the nose cone facing down.

For fitment of unit, remove back cover and mount in desired position using both 8.2mm dia. mounting holes situated on the mounting foot.

Replace back cover prior to applying power to the unit.